



Value stream map and Visilean® for prefabricated concrete panels management

Julia Kanai and Patricia Stella Pucharelli Fontanini



Introduction



IGLC 28

BERKELEY, CA 6-12 JULY 2020

28th ANNUAL CONFERENCE OF THE
INTERNATIONAL GROUP FOR LEAN CONSTRUCTION

- Waste of time and waste of material are the problems in construction due to the lack production flow planning.
- It is important to improve productivity, so the factory can produce more in less time, then the company makes more money.
- Prefabrication has improved productivity and reduced waste of material and labor, because it has more control in factory than in construction site.
- Lean construction also reduce waste, it is supported by two pillars: just-in-time and automation.
- For project flows, a value stream map can improve identification of customer requirements, simultaneous engineering, decision-making and integration of specialized subcontractors.



Lean concepts



IGLC 28

BERKELEY, CA 6-12 JULY 2020

28th ANNUAL CONFERENCE OF THE
INTERNATIONAL GROUP FOR LEAN CONSTRUCTION

- The use of prefabricated building systems requires **process synchronization**, so the assembly process is not interrupted and the stock level is lower.
- **Just-in-time (JIT)** means that the suppliers deliver the correct parts on the construction site when they need it and only in the required quantity.
- **Continuous flow** requires organized layout to avoid interrupting the processes. This helps to drop the production time.
- **Value Stream Map (VSM)** helps you visualize the processes, identify waste and its sources, and see the relationship between the information flow and the material flow





IGLC 28

BERKELEY, CA 6-12 JULY 2020

28th ANNUAL CONFERENCE OF THE
INTERNATIONAL GROUP FOR LEAN CONSTRUCTION

Method

The research was developed at a company in São Paulo (Brazil). The method started from the investigation of the flow of concrete panels produced in the factory, followed by transport to the construction site, the flow of information on design, production, and assembly of the prefabricated parts was investigated. The chosen material, prefabricated concrete panel, has a production line based on the specified design and quantities defined by the factory manager. The authors classify this research as a case study since they observed the material and information flow of a real construction.

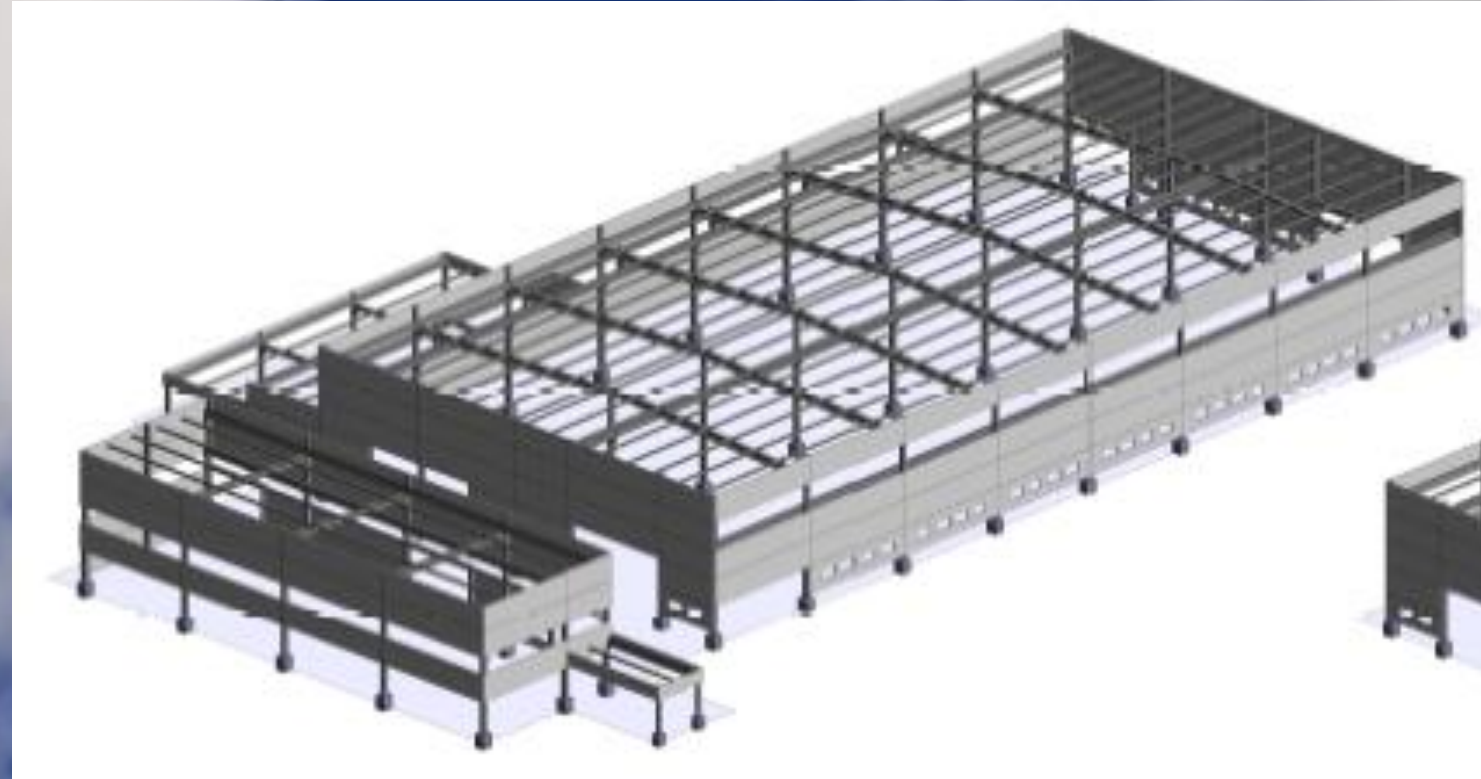

Scenarios

Scenarios	Value flow	Description
Current scenario	Real system	Value stream obtained from factory data collection and interview with company engineers.
Future scenario 1	Pushed system	System pushed between processes of design, production and work, with storage formation among the processes.
Future scenario 2	Pull system	Pull system with frequent deliveries between production and assembly processes and insertion of supermarkets instead of stocks.
Ideal scenario	Just in time system	Lean thinking goal: to provide customers with product they want, when they want it, which is to apply just in time throughout all the process.





IGLC 28

BERKELEY, CA 6-12 JULY 2020

28th ANNUAL CONFERENCE OF THE
INTERNATIONAL GROUP FOR LEAN CONSTRUCTION

Current scenario map

The value stream map of the current scenario is according to the company's schedule dates. On the current map, the flow is pushed with lots of 10 detailed panels every 8 hours, lots of 7 panels per day of production and lots of 10 panels assembled per day on site. In the production stage, a waiting time of 24 hours was considered between concrete curing and withdrawal processes.

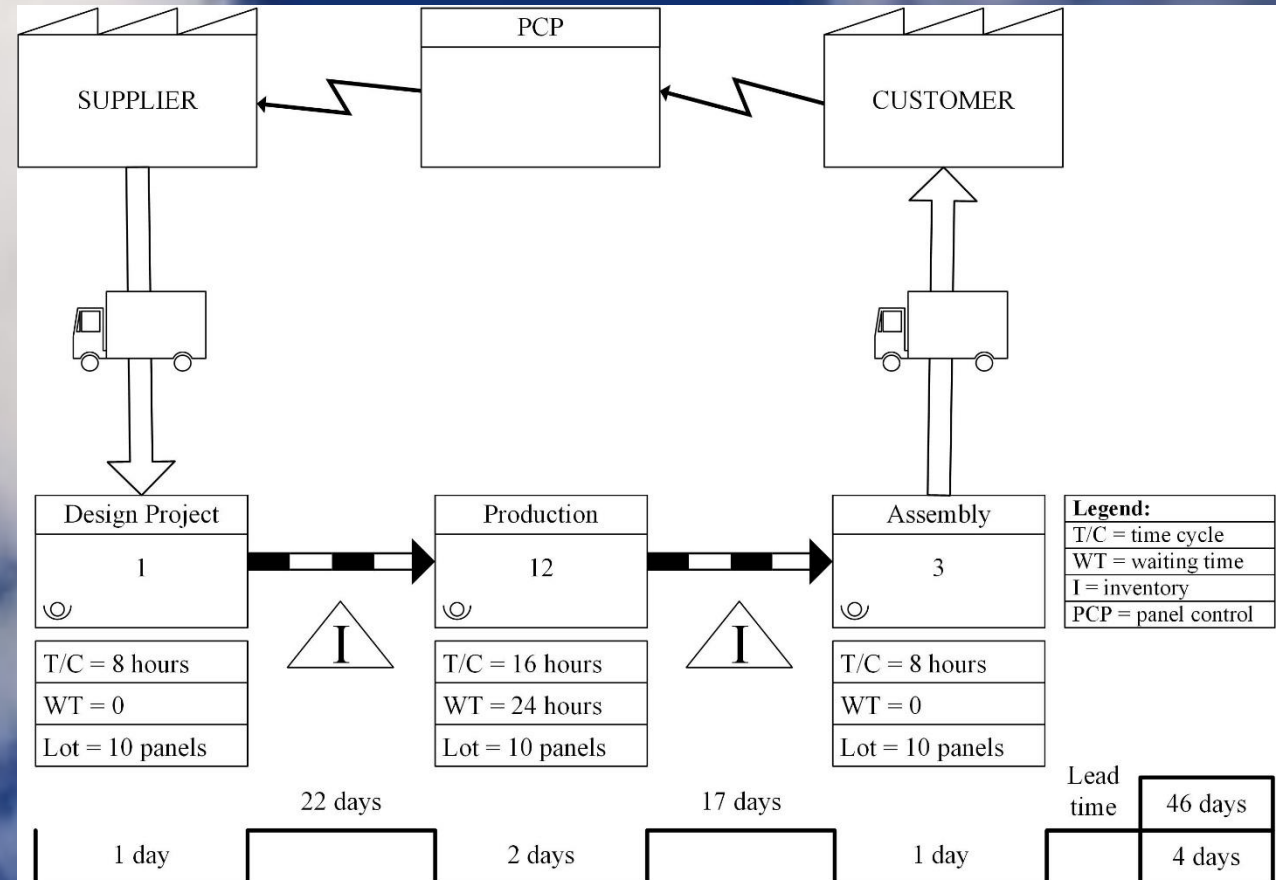

Future scenario 1

For future scenario 1, the flow of materials continues to be pushed and with the formation of inventory of all parts before moving on to the next stage. The purpose of this analysis is to observe how many days would take in a conventional system in which each step needs to be completed in full before moving on to the next step. Therefore, the observed work has 161 panels, detailed designs of all panels must be ready before starting production, then the factory must produce all panels before sending it to the construction site.

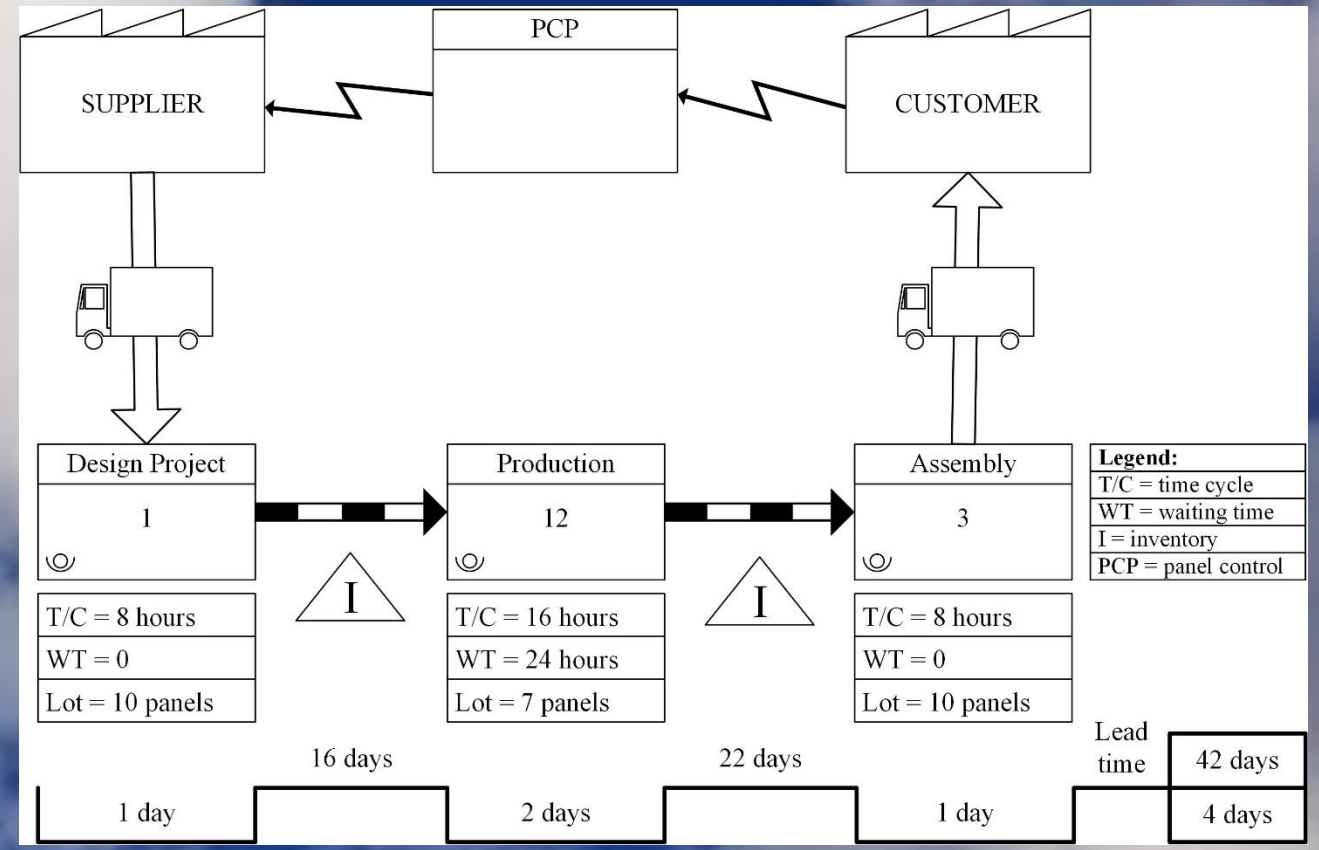



IGLC 28

BERKELEY, CA 6-12 JULY 2020

28th ANNUAL CONFERENCE OF THE
INTERNATIONAL GROUP FOR LEAN CONSTRUCTION

Future scenario 2

In future scenario 2, there is a just-in-time system between production and assembly, eliminating inventory between the two processes. Therefore, the assembly lot must be the same as the production capacity, 7 panels. Thus, everything produced in one day goes to the assembly the next day. Eliminating inventory reduces storage costs, unnecessary movement and frees up space. On this map, the push arrow between the production and assembly process has been replaced by a system pulled level with a supermarket to eliminate inventory. Upon receiving the panels at the construction site, an electronic withdrawal kanban card is sent to production. In the research, VisiLean® is the electronic system that informs the withdrawal of the panel.

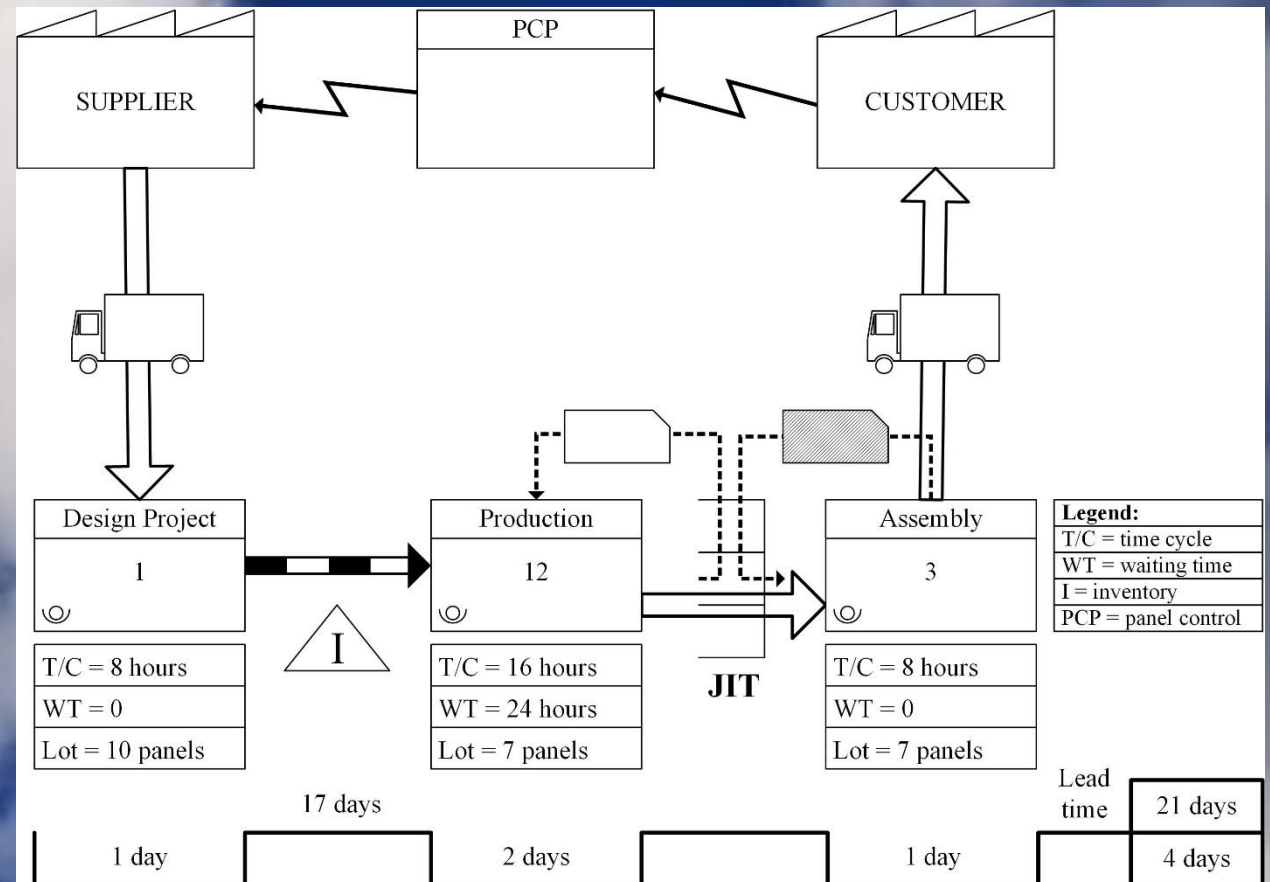

Ideal scenario

In the ideal scenario, the entire flow is just-in-time. To maintain this demand without inventory, it is necessary to prepare projects only for the amount produced the next day and assemble only what is produced. Therefore, the assembly schedule has only 7 panels per day. In this map, there is a leveled system with supermarket between the design and production stages as well, also symbolizing the just-in-time flow and eliminating the inventory. In addition to sending the electronic withdrawal kanban card through VisiLean, there is a collection box for kanban cards to be sent to the company's production control plan (PCP). This will assist in controlling finished parts at each stage.

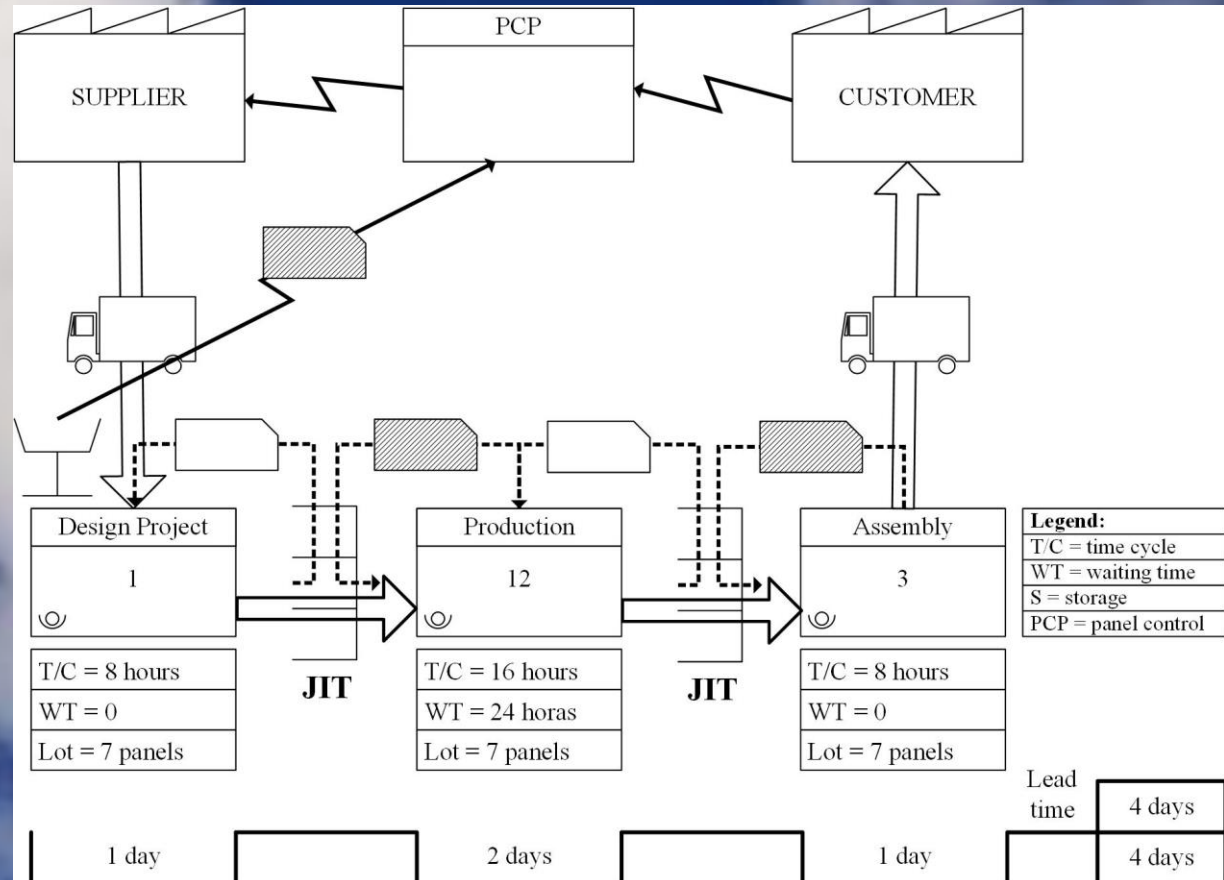

Visilean®



IGLC 28

BERKELEY, CA 6-12 JULY 2020

28th ANNUAL CONFERENCE OF THE
INTERNATIONAL GROUP FOR LEAN CONSTRUCTION

Visilean® provided the visualization of the 3D model of the building, the control of the value flow and the comparison of the scenarios. The 3D model facilitated the visualization of the location of all the prefabricated panels.

The Visilean® app on mobile helped to control the production of the panels. Every complete panel was updated via the mobile app.

This improved communication of the flow, so the teams were aware of the completion of each stage. Visilean® allowed the insertion of the schedules of the four proposed scenarios, so it is possible to compare their duration. So, it was easier to follow the schedule to achieve just in time.

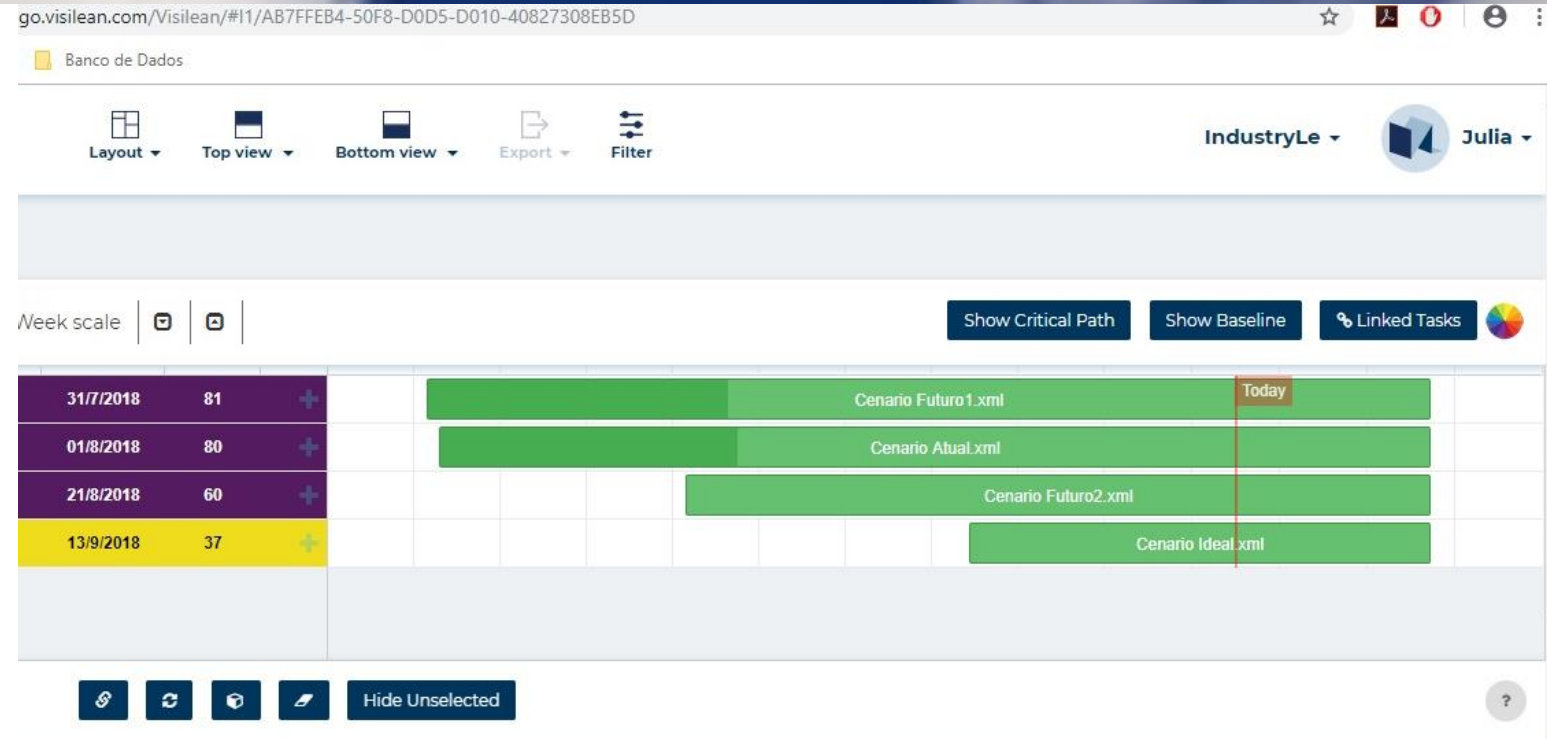

Discussion



IGLC 28

BERKELEY, CA 6-12 JULY 2020

28th ANNUAL CONFERENCE OF THE
INTERNATIONAL GROUP FOR LEAN CONSTRUCTION

- On Visilean®️, we can compare the duration to finish all panels in all scenarios.
- The longest scenario is the Current, but it is almost the same time as the Future 1.
- The Future 1 scenario had a small improvement compared to the current scenario.
- Future scenario 2, on the third line, reduced 25% of the time of the current scenario, which means that transforming the process between manufacturing and assembly in just-in-time reduces the total time.
- The Ideal scenario, in the fourth line, has reduced more than 50% of the time of the current scenario, meaning that it is the most optimized scenario.

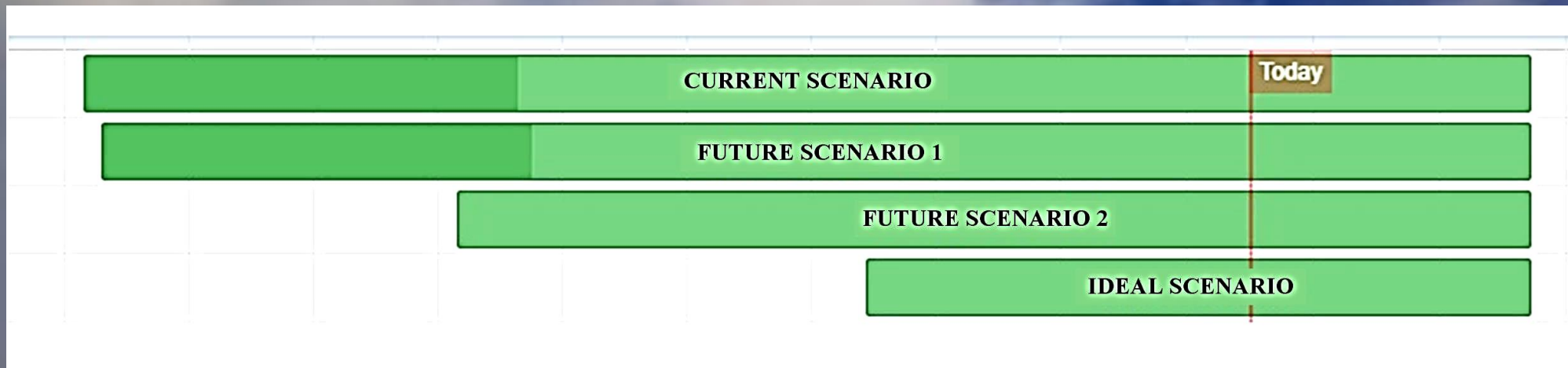

Conclusion



IGLC 28

BERKELEY, CA 6-12 JULY 2020

28th ANNUAL CONFERENCE OF THE
INTERNATIONAL GROUP FOR LEAN CONSTRUCTION

- In theory, the contribution of this research was to achieve just-in-time gradually using four scenarios in Value Stream Maps. The Value Stream Maps helped to manage the design, production, and assembly cycle times.
- In practice, the paper also contributed to show the use of Visilean® for precast panel production management. Therefore, operators were able to view production times and services, as well as their sequence in real-time. Also, the communication between stages had an improvement.
- Despite the factory is remarkably automated, it is important to have continuous improvement. For future research, the suggestion is to include RFID or the Internet of Things to have greater control of flow management.